

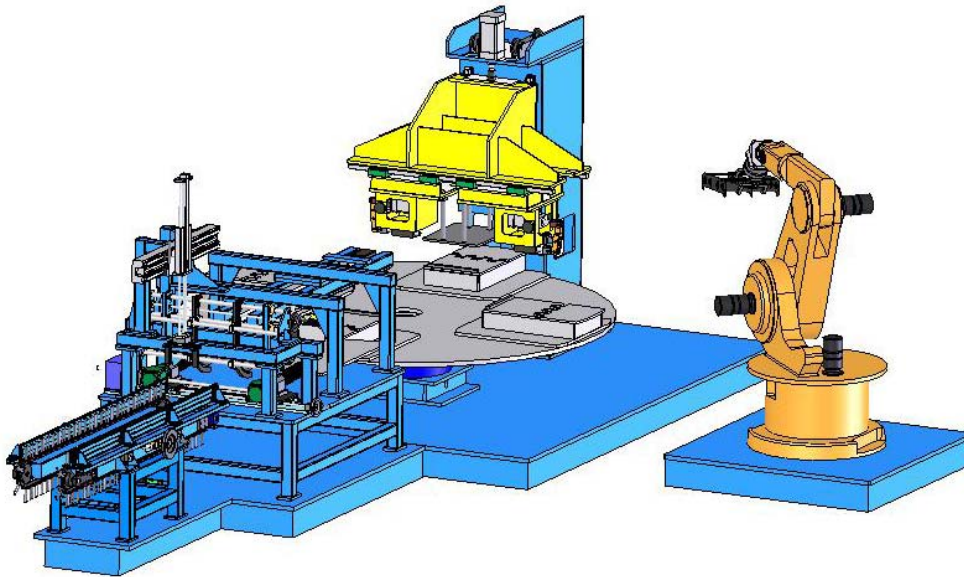

## High volume Core Builder

The TTCB-4 (Turn Table Corebuilder 4-position) is a high volume corebuilder that can produce a range of radiator and condenser cores. The machine uses servo-based controls to ensure precise core assembly dimensions. The TTCB-4 can be configured with varying levels of automation. The standard machine (shown below) includes automatic tube loading into the machine from storage buffer/conveyor and automatic (robotized) braze frame loading/core unloading. Loading of headers and side supports is manual.



*Representative Images of a TTCB-4*

### **TTCB-4 GENERAL CAPABILITY:**

|                                   |                                  |
|-----------------------------------|----------------------------------|
| Operating Rate:                   | Operator Dependent               |
| Tube Length (Header-To-Header):   | 350mm ( ) to 750 mm ( )          |
| Core Height (Stack-Up Dimension): | 200mm ( ) to 600 mm ( )          |
| Core Depth:                       | 14 mm ( ) Min. to 50 mm ( ) Max. |

GEFIT Livernois Engineering LLC

25315 Kean Street, Dearborn, MI 48124  
Tel. (313) 278-0200, Fax (313) 278-5992, [www.livernois.com](http://www.livernois.com)



# GEFIT Livernois Engineering

## AUTOMATED MACHINE CYCLES (Standard Machine)

|                                     |                      |
|-------------------------------------|----------------------|
| Tube Placement into Matrix:         | Automatic/Continuous |
| Fin Placement into Matrix:          | Automatic/Continuous |
| Header Placement into Matrix:       | Manual               |
| Side Support Placement into Matrix: | Manual               |
| Fin Feed:                           | RH & LH Available    |
| Tube Rows:                          | One (1)              |
| Header Assembly:                    | Automatic            |
| Side Support Assembly:              | Automatic            |
| Tube Expand (flared & staked):      | n.a.                 |
| Braze Iron Placement to Tooling     | Automatic/Continuous |
| Braze Frame and Unload assembly     | Automatic/Continuous |

## PRODUCTION RATES

Production rates are dependent upon the core to be produced. A sample production rate of radiators for this machine is:

|                      |  |
|----------------------|--|
| Core Output Rate:    | 120 Cores Per Hour (based on a 39 tube core) |
| Input Fin Feed Rate: | 124 Fins Per Minute (using a 2-out fin mill) |
| Core:                | 39 Tubes/450 mm Long                         |

## GENERAL DESCRIPTION

The core assembly machine will consist of the following:

- Tube Loading buffer/magazine (linear)
- Tube Dispensing System w/ J-Stack
- Matrix Build and Transfer System
- False Tube
- Core Transfer System
- Expandable Table
- Core Press
- Matrix Comb Assembly
- Header Press
- Core Hold Down Assembly
- Automatic braze frame loading
- Braze frames buffer/magazine (turn table)
- Unload robot, w/ gripper
- Corebuilder Base
- Safety Guarding
- Control System
- (1) Set of Operator/Maintenance Manuals

## MACHINE FOOTPRINT:

|                       |                      |
|-----------------------|----------------------|
| Length.....           | 6,900 mm ( )         |
| Width.....            | 8,200 mm ( )         |
| Height.....           | 2,500 mm (8'-2 1/2") |
| Estimated Weight..... | 10,500 kg ( )        |

## STANDARD UTILITY SPECIFICATIONS

|                    |                                  |
|--------------------|----------------------------------|
| Electrical Supply: | 400/480 Volts, 3 Phase, 50/60 Hz |
| Air Supply:        | 5.5 Bar (80 PSI)                 |

GEFIT Livernois Engineering LLC

25315 Kean Street, Dearborn, MI 48124  
Tel. (313) 278-0200, Fax (313) 278-5992, [www.livernois.com](http://www.livernois.com)